



ICON VEHICLE DYNAMICS™

7929 LINCOLN AVE . RIVERSIDE . CA 92504 - P 951.689.4266 / F 951.689.1016

Included Parts:

- (2) 05+ Taco/FJ UCA
- (2) 17-4 Tapered Pin Adapters
- (4) Ungreased Bushing Assemblies
- (8) Washers

Install Instructions

58450: UCA Kit 05+ Toyota Tacoma/07+ Toyota FJ/03+ 4Runner

READ ALL INSTRUCTIONS THOROUGHLY FROM START TO FINISH BEFORE BEGINNING INSTALLATION! IF THESE INSTRUCTIONS ARE NOT PROPERLY FOLLOWED, SEVERE FRAME, SUSPENSION, AND TIRE DAMAGE MAY RESULT TO THE VEHICLE!

Warning! Icon Vehicle Dynamics recommends that you exercise extreme caution when working under a vehicle that is supported with jack stands or on a lift.

1. Lift vehicle and securely place heavy duty jack stands under the MFG recommended lifting locations for the front of the vehicle. Take care when lifting the vehicle, and allow 3-4" of ground clearance from the tire. **NEVER WORK UNDER AN UNSUPPORTED VEHICLE.**
2. Remove front tires.
3. Using a jack, slightly lift the LCA to prevent the arms from being at full droop.
4. Turning the steering wheel to the driver side will allow easy access to the nut on the UCA ball joint that mates the spindle and UCA. Remove the safety cotter pin if present and loosen the ball joint nut.
5. The spindle will need to be supported so as not to tilt over, over extend the CV's on 4wd equipped trucks, or possibly damage steering. Using a ball joint separator, split the ball joint from the spindle. Repeat steps #2 and #3 on the passenger side UCA.
6. With the UCA detached from the spindle begin to loosen the UCA from its mounts in the frame using a wrench and socket and remove OEM UCAs.
7. Before installing your new UCAs, care must be taken to grease the bushings prior to install assembly.
8. Install the tapered pin adapter. Carefully loosen components and slide the pin into the uni-ball pivot. Continue by inserting the dome cap and 1/2" 12pt bolt and tightening the tapered pin assembly.
9. With greased bushings installed, place the driver side UCA into the arm mounts on the chassis and loosely tighten OEM hardware.
10. Take care when inserting tapered pin into the spindle to not damage the threads. Loosely tighten the OEM ball joint nut onto the tapered pin to snug taper into seat. Once aligned and seated, torque nut to factory spec.
11. Once the taper is properly tightened, re-insert the cotter pin and tighten the UCA mounts.
12. Re-install wheel and tighten lug nuts.
13. Vehicle will have to be aligned for caster and camber control.

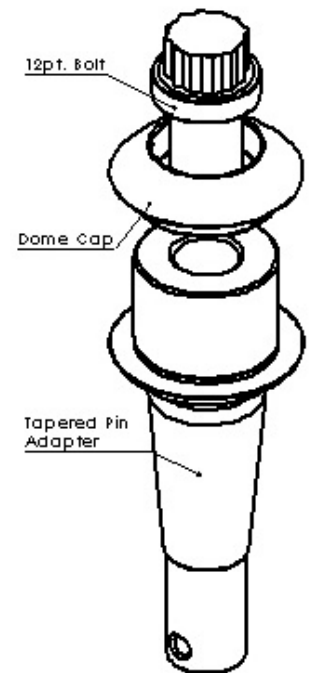

**Special Notes:

(8) Total washers are included. (4) silver and (4) gold. The silver washers are thicker and designed to be placed on the inside of the UCA bushings. Each arm will have 2 gold washers on the outside of the arm bushings, and 2 silver washers on the inside of the arm.

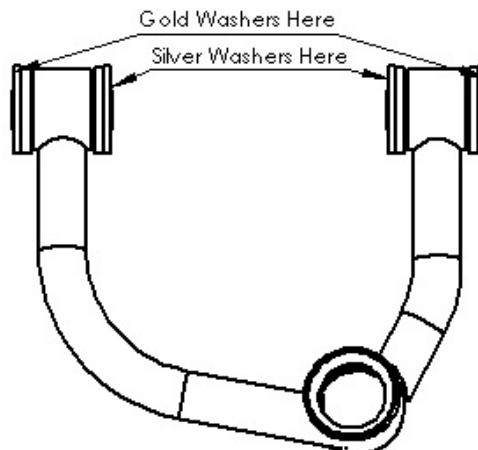

Definitions:

LCA: Lower Control Arm
UCA: Upper Control Arm
OEM: Original Equipment Mfg
CV Joint: Constant Velocity Joint